

LINE

AUTOMATIC TURNTABLE STRETCH WRAPPER

DESCRIPTION

The LINE is the most versatile fully automatic pallet wrapping machine in the turntable range. The basic structure is a reinforced frame with a large bearing capacity specifically designed to withstand the weight of the roller turntable and load.

The LINE is fully automatic. Its turntable is fitted with a powered roller conveyor for automatic in-feed and out-feed of palletised loads. Film is also applied automatically, as per the chosen program.



FEATURES

- Powered Roller Conveyor on the Turntable
- Interfacing for In-feed and Out-feed Conveyors
- Suitable for all Types of Stretching Film
- Different Wrapping Modes and Programs Set Through LCD Control Display
- Powered Film Pre-Stretching (Fixed Ratio Type: Supplied with Four Sets of Gears)
- Soft Start and Adjustable Turntable Speed
- Adjustable Carriage Speed
- Internal Counters for Wrapped Loads, Film Consumption, Etc.
- Automatic Film Gripper and Cutting Arm
- Hot Wire Film Cutting System
- Siemens S7-200 PLC Control
- Harmonics Suppressor Line Filter
- Automatic Pallet Height Detection by Photocell

STANDARD STRAIGHT LINE CONFIGURATION

DIMENSIONS

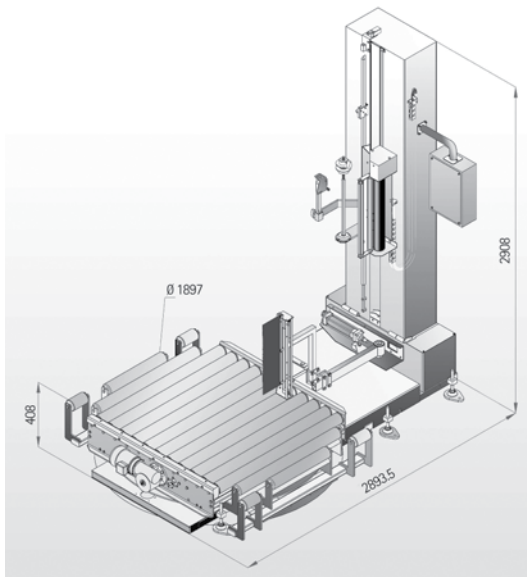

CONTROL PANEL

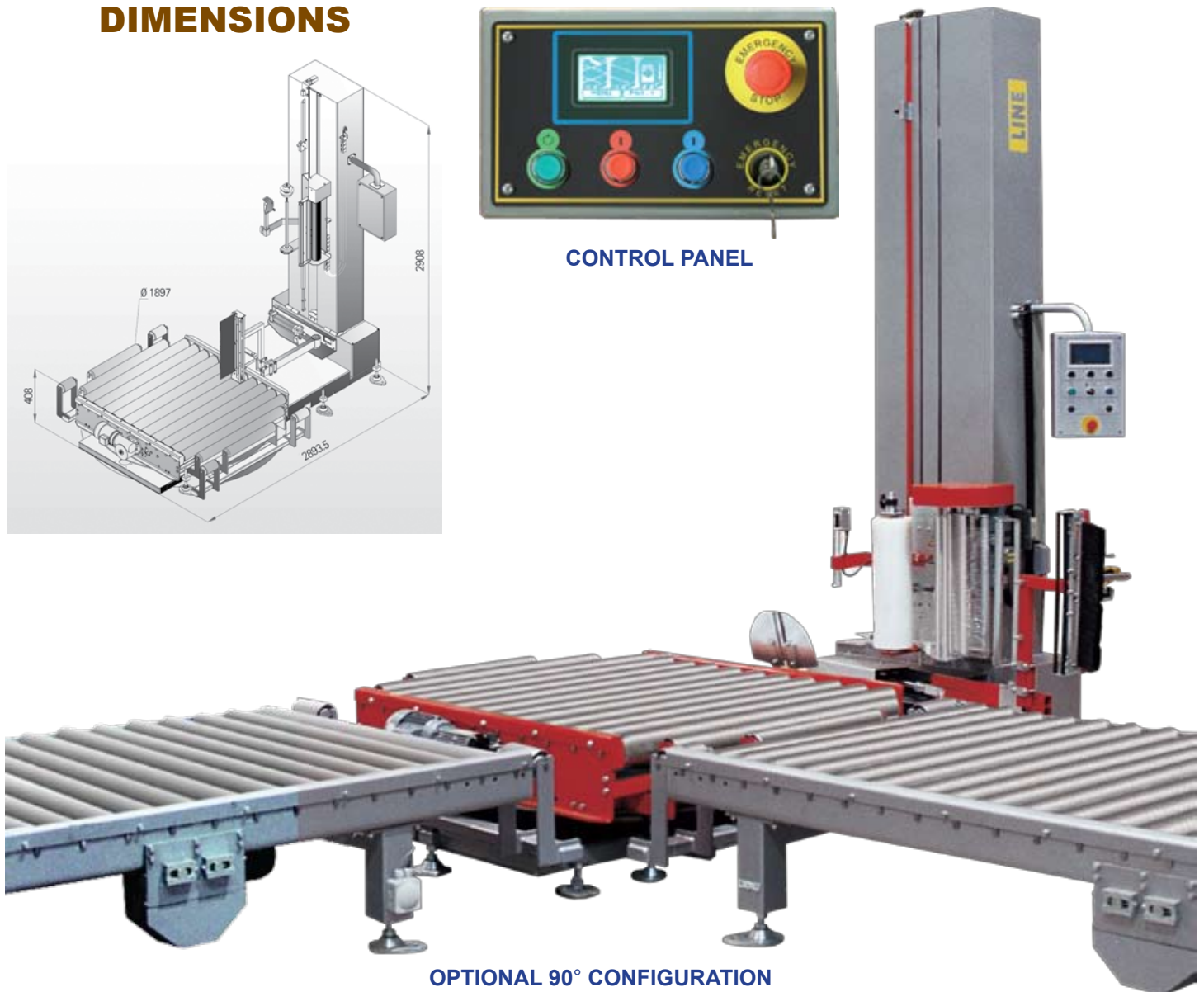

OPTIONAL 90° CONFIGURATION

SPECIFICATIONS

- Maximum Pallet Height: 2,400mm
- Maximum Pallet Size: 1,200mm x 1,200mm
- Maximum Pallet Weight: 1,800kg
- Power Required: 380VAC or 220VAC
- Maximum Power Consumption: 4kW
- Total Weight: 900kg
- Pneumatic Air Pressure: 6 bar
- Air Consumption: 120 litres/minute
- Roller Conveyor Speed: Up to 11.5m/minute
- Output: Up to 50 pallets/hour (Under Suitable Conditions)
- Special Heavy-Duty Axial Bearing on Turntable

OPTIONS

- Sliding Knife Film Cutting Device
- Powered Top Platen to Stabilize Load
- Film Tail Hot Seal (with or without Dolly or Linear).
- 90° In-feed/Out-feed Configuration
- Fully Automatic Top Film Sheet Dispenser
- Film Narrower
- Different Load Sizes
- In-feed/Out-feed Powered Roller Conveyors: 1500mm Length x 1300mm Width
- Muting Light Curtains for Complete Operator Safety