

EC-201 ROBOT PALLETISER

The EC-201 robot offers production rates up to 26 cycles per minute utilising only 6.5kVA.



by



DESCRIPTION

The EC-201 high speed robot is a compilation of years of research and development by Fuji Robotics. This technologically advanced robot offers high capacity rates and a payload weight of 200kg. These points plus other advantages place the EC-201 as the premier solution in a highly competitive marketplace.

This new generation robot provides an ultra-quiet operation, improved efficiencies, and maximum flexibility that accompany "high speed" palletising technology.

TECHNICAL DATA

Model	EC-201
Mechanism	Articulated Robot
Action Mode	Cylindrical
Weight Capacity (Including Hand)	200kg
Palletising Capacity (Cycles/Hour)	1600 Cycles/Hour
Degree of Freedom	4 axes
Operational Space:	
Z Axis (Vertical)	2300mm
R Axis (Longitudinal)	1500mm
θ Axis (Turn)	330°
a Axis (Wrist)	330°
Hand Gripper	Clamp, Fork, Vacuum, Custom Designed
Memory	120 Recipes
Teaching Method	Teaching Playback Teaching Support Teachingless (Option)
Power (200/220V, 3-Phase, 50/60 Hz)	6.5kVA
Main body weight (without hand)	1150kg

NOTE: Capacities stated are the maximum that may be achieved by the robot under ideal conditions. Capacity rates can be significantly affected by layouts, product types, and can only be confirmed after a detailed analysis of an application.

FEATURES

GENERAL

- Ultra quiet operation
- Unique linear guides designed specifically for palletising (Exclusive to Fuji Ace)
- Polycarbonate cover to reduce weight
- EC Series (Energy Conservation) designed to save energy, resources, and money
- Simple, compact and durable design
- Multiple end effector applications for bags, boxes, cases, pails, drums, bottles, and shrink wrapped packages

CUTTING-EDGE CONTROL

Every Fuji Ace robot comes with a touch screen control complete with:

- Pre-programmed pallet patterns embedded in the touch screen to meet your exact specifications
- 60 programmable memory recipes. Once utilized, recipes can be switched within seconds
- Onboard automatic lubrication schedule
- Onboard diagnostics designed to identify errors instantaneously
- Onboard error log history
- Inventory monitoring that corresponds with specific recipes
- High level programming software offering complete onboard control and recipe editing without the need of a laptop computer
- Real time I/O monitoring
- Comes with a user friendly teaching pendant

MECHANICAL ADVANTAGE

- Unique linear track design contributes to decreased power consumption by 50% or more while achieving up to 1600 cycles per hour
- The articulated arm movement is driven by the combination of a servo motor, timing belt, recirculating linear guide bearings and two hardened steel ball screws
- Uses a 5 to 1 movement ratio on the Z axis (arm movement up or down)
- Uses a 6 to 1 movement ratio on the R axis (arm movement in or out)
- The robot pivots (Theta axis) up to 330° on a high density cross roller thrust bearing designed for years of trouble free operation in harsh environments
- The arm end is designed to pivot up to 330°

DIMENSIONS

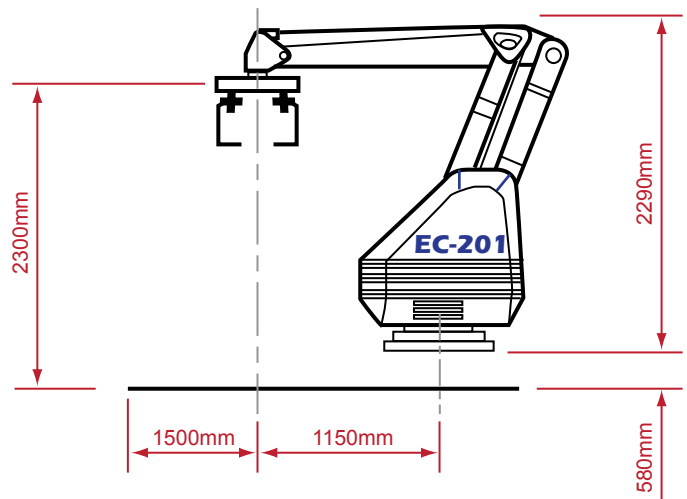

SIDE VIEW

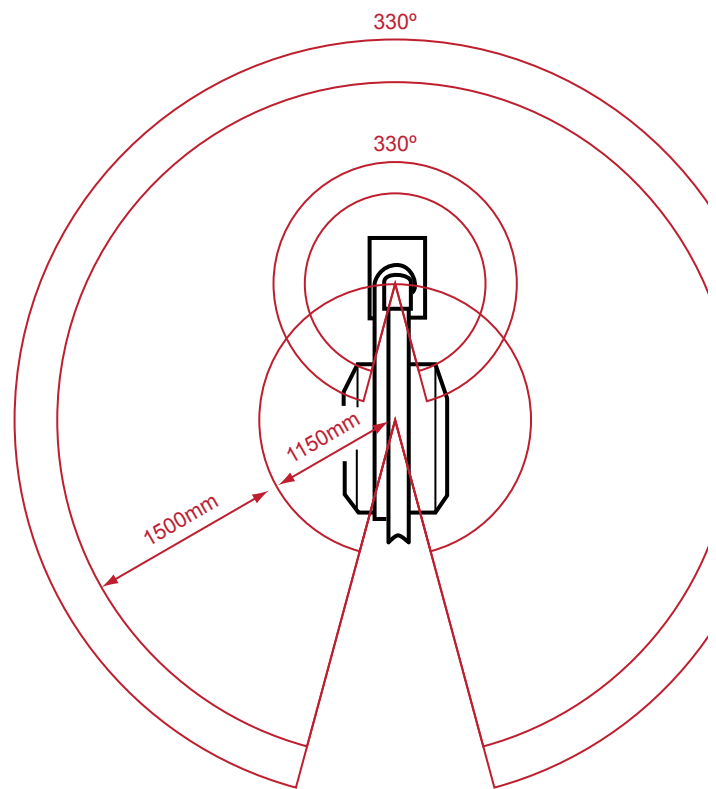

TOP VIEW

OPTIONS

- Cold environment upgrade
- Harsh environment upgrade (stainless steel components)
- Memory program expansion
- Auto reject function
- Simultaneous multi-size product handling (5th axis)
- Slipsheet placement
- Pallet placement